

# 小孔径刀的表达方法

Representation of small caliber cutting tools

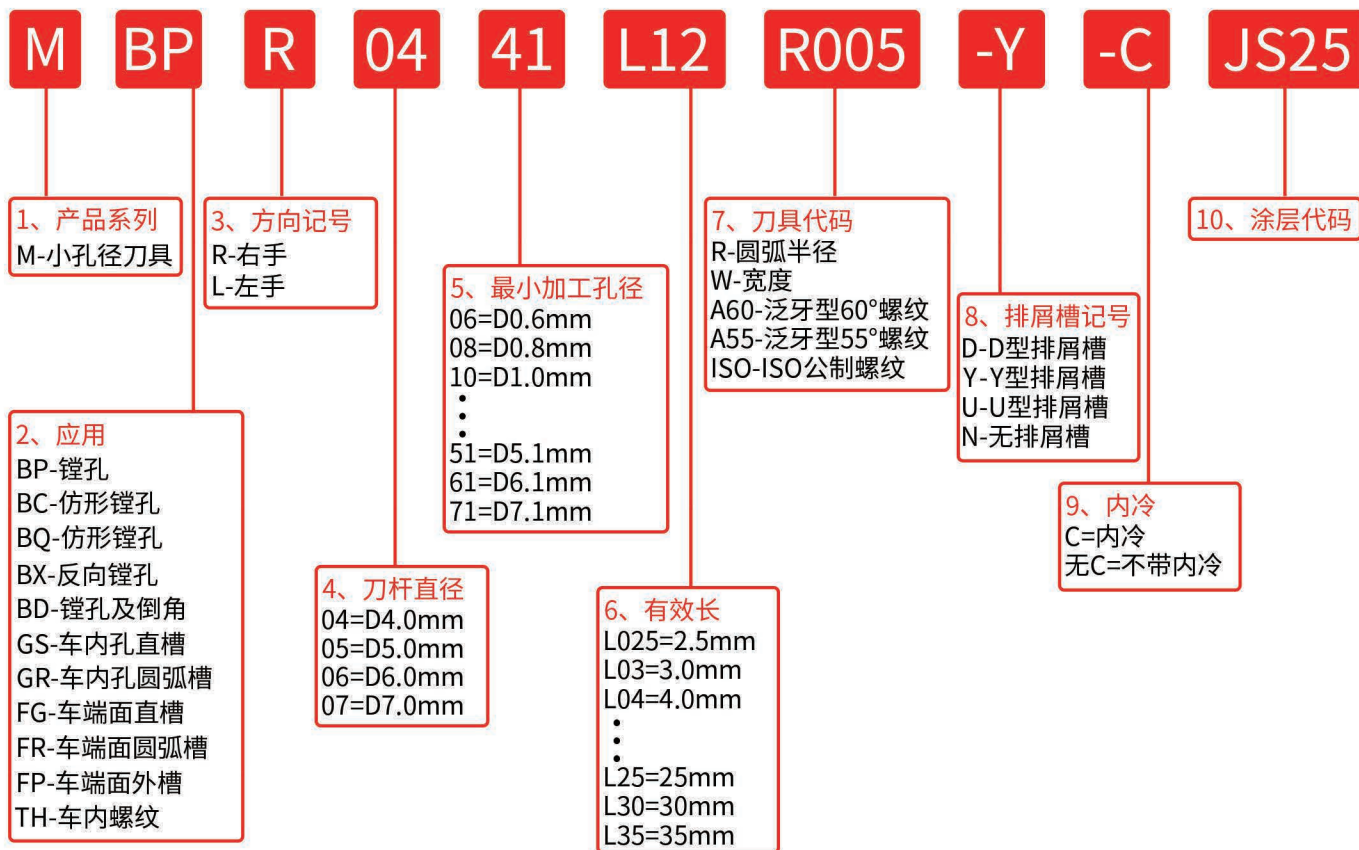

## 免对刀套设计



- 镗刀斜柄设计，配合定位销钉刀套设计，夹持高精稳定可实现免对刀，提升设备稼动率。

## 斜柄定位设计



## 内冷设计

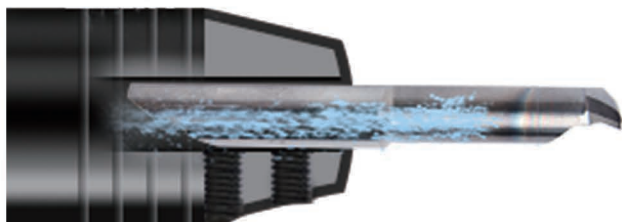

- 镗刀斜柄位侧边开槽设计，配合中心出水刀套，实现内冷加工。



# MBPR

## 内孔镗刀 Internal Boring

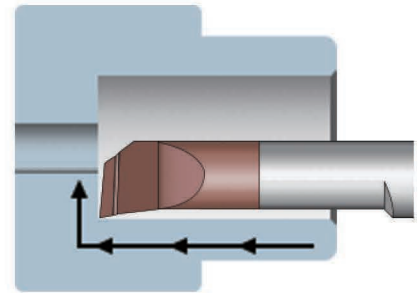
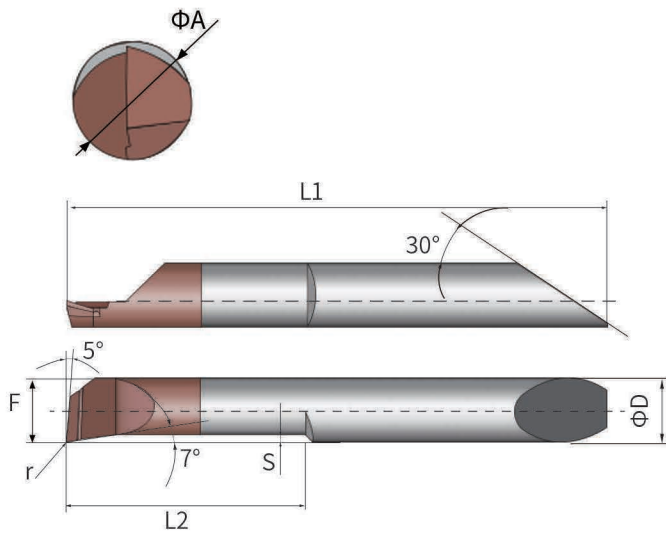

产品型号	最小加工直径 (mm) ΦA	ΦD	r	L1	L2	F	S	JS25	AL25
MBPR0421L06R005-Y-(C)	2.1	4	0.05	31	6	1.85	0.2	●	●
MBPR0421L06R010-Y-(C)	2.1	4	0.10	31	6	1.85	0.2	●	●
MBPR0421L10R005-Y-(C)	2.1	4	0.05	35	10	1.85	0.2	●	●
MBPR0421L10R010-Y-(C)	2.1	4	0.10	35	10	1.85	0.2	●	●
MBPR0426L08R005-Y-(C)	2.6	4	0.05	33	8	2.35	0.25	●	●
MBPR0426L08R010-Y-(C)	2.6	4	0.10	33	8	2.35	0.25	●	●
MBPR0426L08R015-Y-(C)	2.6	4	0.15	33	8	2.35	0.25	●	●
MBPR0426L12R005-Y-(C)	2.6	4	0.05	37	12	2.35	0.25	●	●
MBPR0426L12R010-Y-(C)	2.6	4	0.10	37	12	2.35	0.25	●	●
MBPR0426L12R015-Y-(C)	2.6	4	0.15	37	12	2.35	0.25	●	●
MBPR0431L10R005-Y-(C)	3.1	4	0.05	35	10	2.8	0.30	●	●
MBPR0431L10R010-Y-(C)	3.1	4	0.10	35	10	2.8	0.30	●	●
MBPR0431L10R015-Y-(C)	3.1	4	0.15	35	10	2.8	0.30	●	●
MBPR0431L15R005-Y-(C)	3.1	4	0.05	40	15	2.8	0.30	●	●
MBPR0431L15R010-Y-(C)	3.1	4	0.10	40	15	2.8	0.30	●	●
MBPR0431L15R015-Y-(C)	3.1	4	0.15	40	15	2.8	0.30	●	●
MBPR0441L12R005-Y-(C)	4.1	4	0.05	37	12	3.8	0.40	●	●
MBPR0441L12R010-Y-(C)	4.1	4	0.10	37	12	3.8	0.40	●	●
MBPR0441L12R020-Y-(C)	4.1	4	0.20	37	12	3.8	0.40	●	●
MBPR0441L16R005-Y-(C)	4.1	4	0.05	41	16	3.8	0.40	●	●
MBPR0441L16R010-Y-(C)	4.1	4	0.10	41	16	3.8	0.40	●	●
MBPR0441L16R020-Y-(C)	4.1	4	0.20	41	16	3.8	0.40	●	●
MBPR0441L20R005-Y-(C)	4.1	4	0.05	45	20	3.8	0.40	●	●
MBPR0441L20R010-Y-(C)	4.1	4	0.10	45	20	3.8	0.40	●	●
MBPR0441L20R020-Y-(C)	4.1	4	0.20	45	20	3.8	0.40	●	●
MBPR0551L15R010-Y-(C)	5.1	5	0.10	40	15	4.8	0.50	●	●
MBPR0551L15R020-Y-(C)	5.1	5	0.20	40	15	4.8	0.50	●	●
MBPR0551L20R010-Y-(C)	5.1	5	0.10	45	20	4.8	0.50	●	●
MBPR0551L20R020-Y-(C)	5.1	5	0.20	45	20	4.8	0.50	●	●
MBPR0551L25R010-Y-(C)	5.1	5	0.10	50	25	4.8	0.50	●	●
MBPR0551L25R020-Y-(C)	5.1	5	0.20	50	25	4.8	0.50	●	●
MBPR0661L15R010-Y-(C)	6.1	6	0.10	40	15	5.8	0.60	●	●
MBPR0661L15R020-Y-(C)	6.1	6	0.20	40	15	5.8	0.60	●	●
MBPR0661L20R010-Y-(C)	6.1	6	0.10	45	20	5.8	0.60	●	●
MBPR0661L20R020-Y-(C)	6.1	6	0.20	45	20	5.8	0.60	●	●
MBPR0661L25R010-Y-(C)	6.1	6	0.10	50	25	5.8	0.60	●	●
MBPR0661L25R020-Y-(C)	6.1	6	0.20	50	25	5.8	0.60	●	●
MBPR0661L30R010-Y-(C)	6.1	6	0.10	55	30	5.8	0.60	●	●
MBPR0661L30R020-Y-(C)	6.1	6	0.20	55	30	5.8	0.60	●	●
MBPR0771L25R010-Y-(C)	7.1	7	0.10	54	25	6.8	0.70	●	●
MBPR0771L25R020-Y-(C)	7.1	7	0.20	54	25	6.8	0.70	●	●
MBPR0771L35R010-Y-(C)	7.1	7	0.10	64	35	6.8	0.70	●	●
MBPR0771L35R020-Y-(C)	7.1	7	0.20	64	35	6.8	0.70	●	●

● 有库存 (C) 代表可内冷定制

# MBQR

## 仿形镗刀 Profiling and Boring

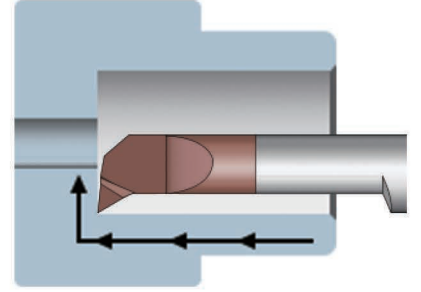
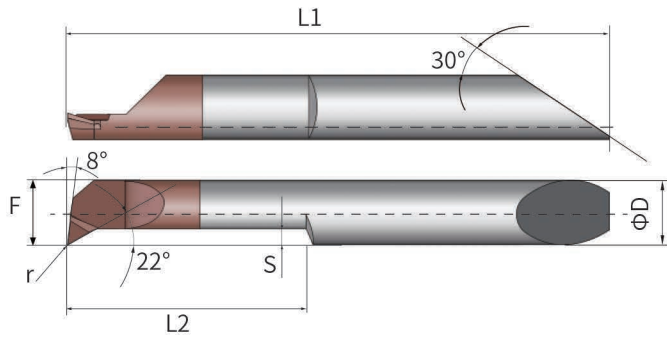
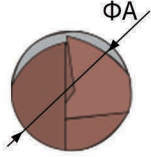

产品型号	最小加工直径 (mm) ΦA	ΦD	r	L1	L2	F	S	JS25	AL25
MBQR0406L02R003-D-(C)	0.6	4	0.03	28	2	0.55	0.06	●	●
MBQR0408L025R003-D-(C)	0.8	4	0.03	28	2.5	0.75	0.08	●	●
MBQR0410L04R005-D-(C)	1.0	4	0.05	29	4	0.9	0.15	●	●
MBQR0410L06R005-D-(C)	1.0	4	0.05	31	6	0.9	0.15	●	●
MBQR0412L04R005-D-(C)	1.2	4	0.05	29	4	1.1	0.15	●	●
MBQR0412L06R005-D-(C)	1.2	4	0.05	31	6	1.1	0.15	●	●
MBQR0415L05R005-D-(C)	1.5	4	0.05	30	5	1.4	0.20	●	●
MBQR0415L05R010-D-(C)	1.5	4	0.10	30	5	1.4	0.20	●	●
MBQR0415L08R005-D-(C)	1.5	4	0.05	33	8	1.4	0.20	●	●
MBQR0415L08R010-D-(C)	1.5	4	0.10	33	8	1.4	0.20	●	●
MBQR0418L05R005-D-(C)	1.8	4	0.05	30	5	1.7	0.20	●	●
MBQR0418L05R010-D-(C)	1.8	4	0.10	30	5	1.7	0.20	●	●
MBQR0418L09R005-D-(C)	1.8	4	0.05	34	9	1.7	0.20	●	●
MBQR0418L09R010-D-(C)	1.8	4	0.10	34	9	1.7	0.20	●	●
MBQR0421L06R005-D-(C)	2.1	4	0.05	31	6	1.85	0.25	●	●
MBQR0421L06R010-D-(C)	2.1	4	0.10	31	6	1.85	0.25	●	●
MBQR0421L10R005-D-(C)	2.1	4	0.05	35	10	1.85	0.25	●	●
MBQR0421L10R010-D-(C)	2.1	4	0.10	35	10	1.85	0.25	●	●
MBQR0426L08R005-D-(C)	2.6	4	0.05	33	8	2.35	0.30	●	●
MBQR0426L08R010-D-(C)	2.6	4	0.10	33	8	2.35	0.30	●	●
MBQR0426L08R015-D-(C)	2.6	4	0.15	33	8	2.35	0.30	●	●
MBQR0426L12R005-D-(C)	2.6	4	0.05	37	12	2.35	0.30	●	●
MBQR0426L12R010-D-(C)	2.6	4	0.10	37	12	2.35	0.30	●	●
MBQR0426L12R015-D-(C)	2.6	4	0.15	37	12	2.35	0.30	●	●
MBQR0431L10R005-D-(C)	3.1	4	0.05	35	10	2.8	0.50	●	●
MBQR0431L10R010-D-(C)	3.1	4	0.10	35	10	2.8	0.50	●	●
MBQR0431L10R015-D-(C)	3.1	4	0.15	35	10	2.8	0.50	●	●
MBQR0431L15R005-D-(C)	3.1	4	0.05	40	15	2.8	0.50	●	●
MBQR0431L15R010-D-(C)	3.1	4	0.10	40	15	2.8	0.50	●	●
MBQR0431L15R015-D-(C)	3.1	4	0.15	40	15	2.8	0.50	●	●

● 有库存 (C) 代表可内冷定制

# MBQR

## 仿形镗刀 Profiling and Boring

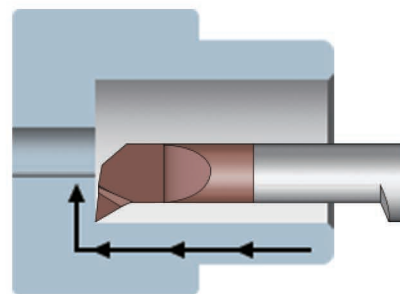
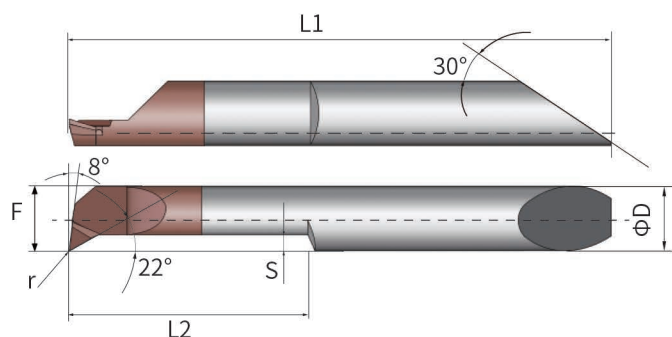
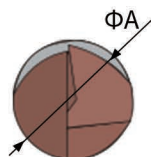

产品型号	最小加工直径 (mm) ΦA	ΦD	r	L1	L2	F	S	JS25	AL25
MBQR0441L12R005-D-(C)	4.1	4	0.05	37	12	3.8	0.60	●	●
MBQR0441L12R010-D-(C)	4.1	4	0.10	37	12	3.8	0.60	●	●
MBQR0441L12R020-D-(C)	4.1	4	0.20	37	12	3.8	0.60	●	●
MBQR0441L16R005-D-(C)	4.1	4	0.05	41	16	3.8	0.60	●	●
MBQR0441L16R010-D-(C)	4.1	4	0.10	41	16	3.8	0.60	●	●
MBQR0441L16R020-D-(C)	4.1	4	0.20	41	16	3.8	0.60	●	●
MBQR0441L20R005-D-(C)	4.1	4	0.05	45	20	3.8	0.60	●	●
MBQR0441L20R010-D-(C)	4.1	4	0.10	45	20	3.8	0.60	●	●
MBQR0441L20R020-D-(C)	4.1	4	0.20	45	20	3.8	0.60	●	●
MBQR0551L15R005-D-(C)	5.1	5	0.05	40	15	4.8	0.80	●	●
MBQR0551L15R010-D-(C)	5.1	5	0.10	40	15	4.8	0.80	●	●
MBQR0551L15R020-D-(C)	5.1	5	0.20	40	15	4.8	0.80	●	●
MBQR0551L20R005-D-(C)	5.1	5	0.05	45	20	4.8	0.80	●	●
MBQR0551L20R010-D-(C)	5.1	5	0.10	45	20	4.8	0.80	●	●
MBQR0551L20R020-D-(C)	5.1	5	0.20	45	20	4.8	0.80	●	●
MBQR0551L25R005-D-(C)	5.1	5	0.05	50	25	4.8	0.80	●	●
MBQR0551L25R010-D-(C)	5.1	5	0.10	50	25	4.8	0.80	●	●
MBQR0551L25R020-D-(C)	5.1	5	0.20	50	25	4.8	0.80	●	●
MBQR0661L15R005-D-(C)	6.1	6	0.05	40	15	5.8	1.00	●	●
MBQR0661L15R010-D-(C)	6.1	6	0.10	40	15	5.8	1.00	●	●
MBQR0661L15R020-D-(C)	6.1	6	0.20	40	15	5.8	1.00	●	●
MBQR0661L20R005-D-(C)	6.1	6	0.05	45	20	5.8	1.00	●	●
MBQR0661L20R010-D-(C)	6.1	6	0.10	45	20	5.8	1.00	●	●
MBQR0661L20R020-D-(C)	6.1	6	0.20	45	20	5.8	1.00	●	●
MBQR0661L25R005-D-(C)	6.1	6	0.05	50	25	5.8	1.00	●	●
MBQR0661L25R010-D-(C)	6.1	6	0.10	50	25	5.8	1.00	●	●
MBQR0661L25R020-D-(C)	6.1	6	0.20	50	25	5.8	1.00	●	●
MBQR0661L30R005-D-(C)	6.1	6	0.05	55	30	5.8	1.00	●	●
MBQR0661L30R010-D-(C)	6.1	6	0.10	55	30	5.8	1.00	●	●
MBQR0661L30R020-D-(C)	6.1	6	0.20	55	30	5.8	1.00	●	●
MBQR0771L25R010-D-(C)	7.1	7	0.10	54	25	6.8	1.20	●	●
MBQR0771L25R020-D-(C)	7.1	7	0.20	54	25	6.8	1.20	●	●
MBQR0771L35R010-D-(C)	7.1	7	0.10	64	35	6.8	1.20	●	●
MBQR0771L35R020-D-(C)	7.1	7	0.20	64	35	6.8	1.20	●	●

● 有库存 (C) 代表可内冷定制

# MBCR

## 仿形镗刀 Profiling and Boring

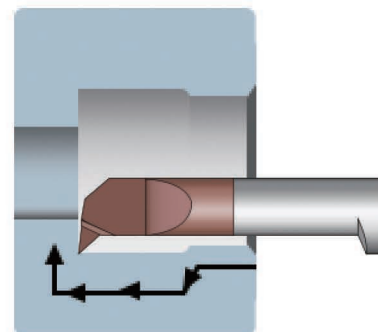
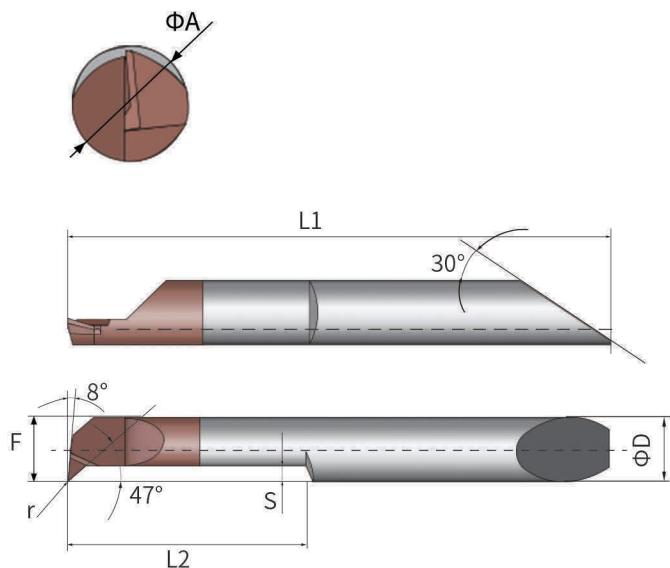

产品型号	最小加工直径 (mm) ΦA	ΦD	r	L1	L2	F	S	JS25	AL25
MBCR0431L10R005-D-(C)	3.1	4	0.05	35	10	2.8	0.60	●	●
MBCR0431L10R010-D-(C)	3.1	4	0.10	35	10	2.8	0.60	●	●
MBCR0431L12R005-D-(C)	3.1	4	0.05	37	12	2.8	0.60	●	●
MBCR0431L12R010-D-(C)	3.1	4	0.10	37	12	2.8	0.60	●	●
MBCR0441L12R005-D-(C)	4.1	4	0.05	37	12	3.8	0.80	●	●
MBCR0441L12R010-D-(C)	4.1	4	0.10	37	12	3.8	0.80	●	●
MBCR0441L16R005-D-(C)	4.1	4	0.05	41	16	3.8	0.80	●	●
MBCR0441L16R010-D-(C)	4.1	4	0.10	41	16	3.8	0.80	●	●
MBCR0551L20R005-D-(C)	5.1	5	0.05	45	20	4.8	1.00	●	●
MBCR0551L20R015-D-(C)	5.1	5	0.15	45	20	4.8	1.00	●	●
MBCR0551L25R005-D-(C)	5.1	5	0.05	50	25	4.8	1.00	●	●
MBCR0551L25R015-D-(C)	5.1	5	0.15	50	25	4.8	1.00	●	●
MBCR0661L20R005-D-(C)	6.1	6	0.05	45	20	5.8	1.20	●	●
MBCR0661L20R015-D-(C)	6.1	6	0.15	45	20	5.8	1.20	●	●
MBCR0661L25R005-D-(C)	6.1	6	0.05	50	25	5.8	1.20	●	●
MBCR0661L25R015-D-(C)	6.1	6	0.15	50	25	5.8	1.20	●	●
MBCR0661L30R005-D-(C)	6.1	6	0.05	55	30	5.8	1.20	●	●
MBCR0661L30R015-D-(C)	6.1	6	0.15	55	30	5.8	1.20	●	●

● 有库存 (C) 代表可内冷定制

# MBXR

## 反向镗刀 Reverse boring cutter

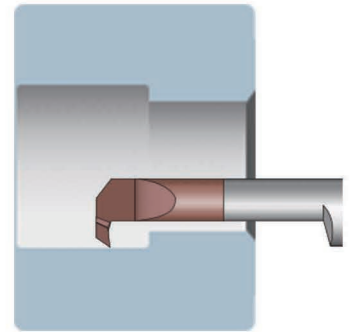
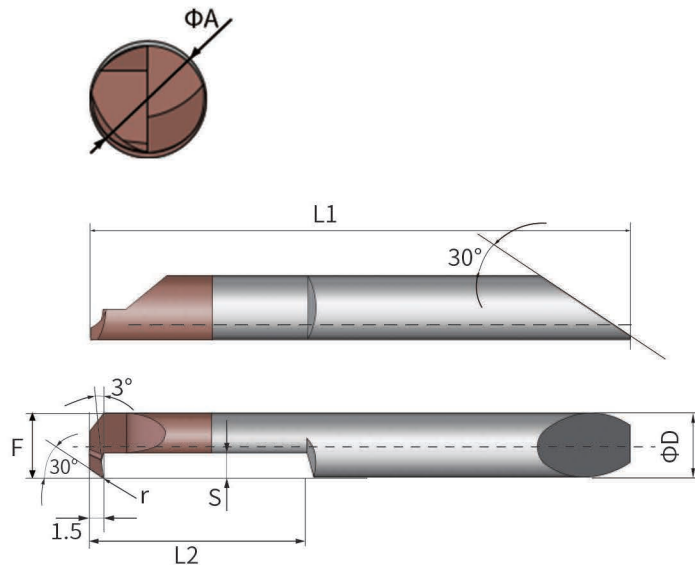

产品型号	最小加工直径 (mm) $\Phi A$	$\Phi D$	$r$	$L1$	$L2$	$F$	$S$	JS25	AL25
MBXR0441L16R010-D-(C)	4.1	4	0.10	41	16	3.8	1.00	●	●
MBXR0551L20R010-D-(C)	5.1	5	0.10	45	20	4.8	1.30	●	●
MBXR0661L25R010-D-(C)	6.1	6	0.10	50	25	5.8	1.60	●	●

● 有库存 (C) 代表可内冷定制

# MGSR

## 内孔切槽刀 Internal Grooving

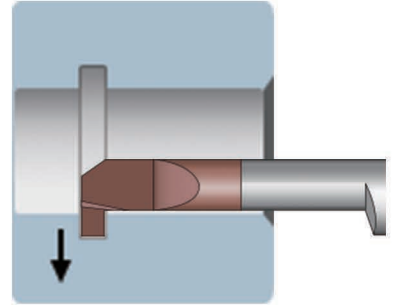
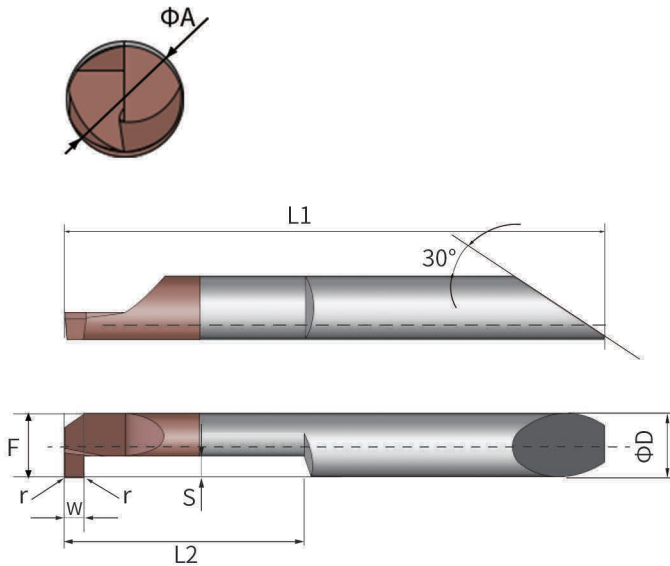

产品型号	最小加工直径 (mm) ΦA	ΦD	r±0.01	L1	L2	F	S	W	JS25	AL25
MGSR0431L10W050-D-(C)	3.1	4	0.05	35	10	2.8	0.80	0.50	●	●
MGSR0431L10W075-D-(C)	3.1	4	0.05	35	10	2.8	0.80	0.75	●	●
MGSR0431L10W100-D-(C)	3.1	4	0.05	35	10	2.8	0.80	1.00	●	●
MGSR0441L12W050-D-(C)	4.1	4	0.05	37	12	3.8	1.00	0.50	●	●
MGSR0441L12W075-D-(C)	4.1	4	0.05	37	12	3.8	1.00	0.75	●	●
MGSR0441L12W100-D-(C)	4.1	4	0.05	37	12	3.8	1.00	1.00	●	●
MGSR0441L12W150-D-(C)	4.1	4	0.05	37	12	3.8	1.00	1.50	●	●
MGSR0551L15W100-D-(C)	5.1	5	0.10	40	15	4.8	1.50	1.00	●	●
MGSR0551L15W150-D-(C)	5.1	5	0.10	40	15	4.8	1.50	1.50	●	●
MGSR0551L15W200-D-(C)	5.1	5	0.10	40	15	4.8	1.50	2.00	●	●
MGSR0661L20W100-D-(C)	6.1	6	0.10	45	20	5.8	2.00	1.00	●	●
MGSR0661L20W150-D-(C)	6.1	6	0.10	45	20	5.8	2.00	1.50	●	●
MGSR0661L20W200-D-(C)	6.1	6	0.10	45	20	5.8	2.00	2.00	●	●
MGSR0771L25W100-D-(C)	7.1	7	0.10	54	25	6.8	2.00	1.00	●	●
MGSR0771L25W150-D-(C)	7.1	7	0.10	54	25	6.8	2.00	1.50	●	●
MGSR0771L25W200-D-(C)	7.1	7	0.10	54	25	6.8	2.50	2.00	●	●

● 有库存 (C) 代表可内冷定制

# MTHR

## 内孔泛用螺纹镗刀 Internal Threading

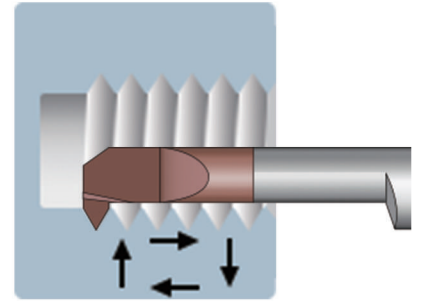
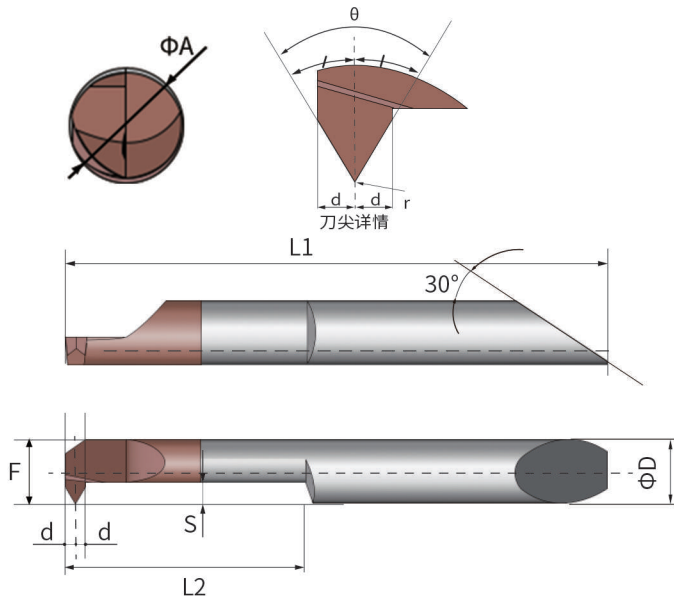

60°范围牙

产品型号	最小加工直径 (mm) $\Phi A$	$\Phi D$	r	L1	L2	F	S	$\theta$	Pitch Range 螺距范围	JS25	AL25
MTHR0415L04A60-N-(C)	1.5	4	0.03	29	4	1.4	0.4	60°	P0.25~P0.4	●	●
MTHR0420L06A60-N-(C)	2.0	4	0.03	31	6	1.9	0.5	60°	P0.25~P0.5	●	●
MTHR0425L08A60-N-(C)	2.5	4	0.03	33	8	2.4	0.6	60°	P0.25~P0.6	●	●
MTHR0430L10A60-N-(C)	3.0	4	0.05	35	10	2.9	1.0	60°	P0.4~P0.8	●	●
MTHR0441L12A60X-N-(C)	4.0	4	0.05	37	12	3.9	1.2	60°	P0.4~P1.0	●	●
MTHR0441L12A60-N-(C)	4.0	4	0.10	37	12	3.9	1.2	60°	P0.8~P1.0	●	●
MTHR0551L15A60X-N-(C)	5.0	5	0.05	40	15	4.9	1.5	60°	P0.4~P1.5	●	●
MTHR0551L15A60-N-(C)	5.0	5	0.10	40	15	4.9	1.5	60°	P0.8~P1.5	●	●
MTHR0661L20A60X-N-(C)	6.0	6	0.05	45	20	5.9	1.8	60°	P0.4~P1.75	●	●
MTHR0661L20A60-N-(C)	6.0	6	0.10	45	20	5.9	1.8	60°	P0.8~P1.75	●	●

● 有库存 (C) 代表可内冷定制



# MTHR

## 内孔泛用螺纹镗刀 Internal Threading

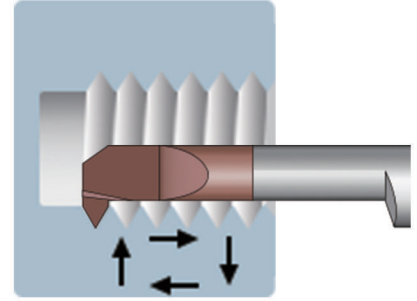
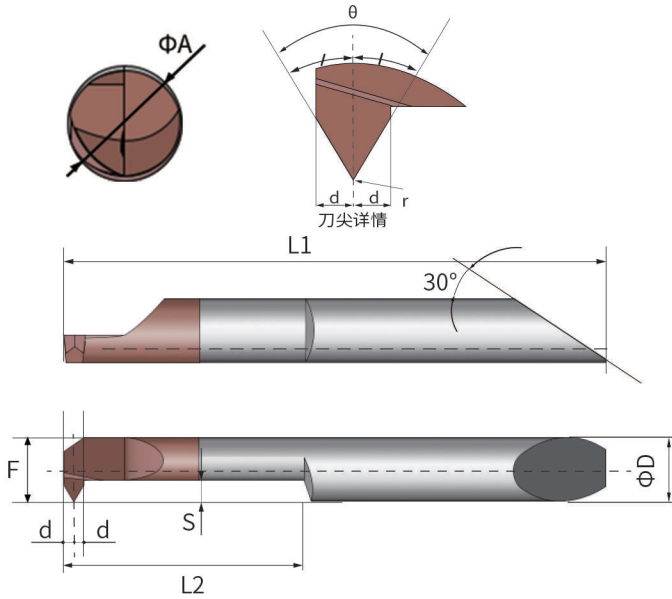

55°范围牙

产品型号	最小加工直径 (mm) ΦA	ΦD	r	L1	L2	F	S	θ	Pitch Range 螺距范围	JS25	AL25
MTHR0431L10A55-N-(C)	3.1	4	0.05	35	10	2.9	1.0	55°	48-24	●	●
MTHR0441L12A55-N-(C)	4.1	4	0.05	37	12	3.9	1.2	55°	48-24	●	●
MTHR0551L15A55-N-(C)	5.1	5	0.08	40	15	4.9	1.6	55°	48-16	●	●
MTHR0661L20A55-N-(C)	6.1	6	0.08	45	20	5.9	1.9	55°	48-12	●	●
MTHR0771L25A55-N-(C)	7.1	7	0.15	54	25	7.9	2.5	55°	26-11	●	●

● 有库存 (C) 代表可内冷定制

# MFGR

## 端面槽刀 Face Grooving

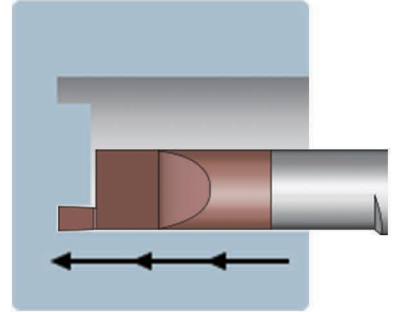
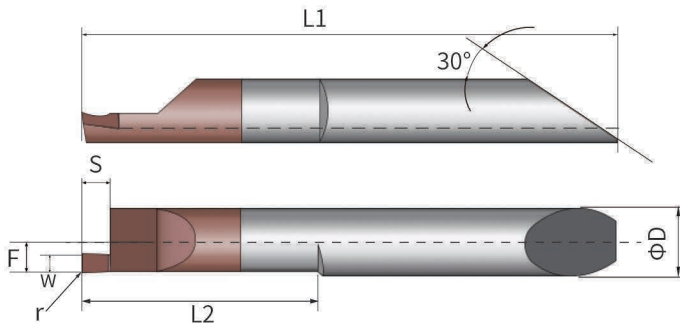
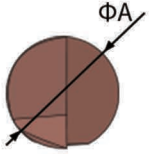

产品型号	最小加工 环径 (mm) ΦA	ΦD	r	L1	L2	F	S	W	JS25	AL25
MFGR0450L12W050-U-(C)	5.0	4	0.05	37	12	1.9	1.00	0.50	●	●
MFGR0450L12W100-U-(C)	5.0	4	0.05	37	12	1.9	1.50	1.00	●	●
MFGR0450L12W150-U-(C)	5.0	4	0.05	37	12	1.9	2.00	1.50	●	●
MFGR0560L15W100-U-(C)	6.0	5	0.10	40	15	2.4	1.50	1.00	●	●
MFGR0560L15W150-U-(C)	6.0	5	0.10	40	15	2.4	2.50	1.50	●	●
MFGR0560L15W200-U-(C)	6.0	5	0.10	40	15	2.4	3.00	2.00	●	●
MFGR0680L20W100-U-(C)	8.0	6	0.10	45	20	2.9	2.00	1.00	●	●
MFGR0680L20W150-U-(C)	8.0	6	0.10	45	20	2.9	3.00	1.50	●	●
MFGR0680L20W200-U-(C)	8.0	6	0.10	45	20	2.9	5.00	2.00	●	●
MFGR0680L20W300-U-(C)	8.0	6	0.10	45	20	2.9	6.00	3.00	●	●

● 有库存 (C) 代表可内冷定制

# 微型小镗刀变径套刀杆

Tiny Tools Toolholders

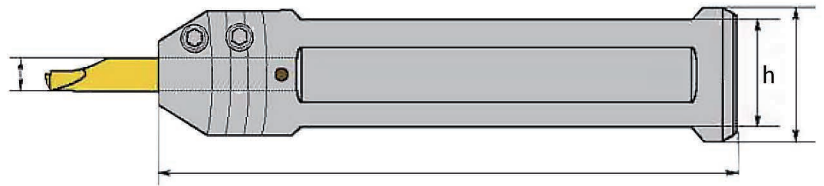

产品型号	D	D1	L	h	夹紧螺钉
SIM0012-D4	12	4.0	75	11	T0507
SIM0012-D5	12	5.0	75	11	T0507
SIM0012-D6	12	6.0	75	11	T0507
SIM0016-D4	16	4.0	75	14	T0507
SIM0016-D5	16	5.0	75	14	T0507
SIM0016-D6	16	6.0	75	14	T0507
SIM0016-D7	16	7.0	75	14	T0507
SIM0020-D4	20	4.0	90	18	T0507
SIM0020-D5	20	5.0	90	18	T0507
SIM0020-D6	20	6.0	90	18	T0507
SIM0020-D7	20	7.0	90	18	T0507
SIM0022-D4	22	4.0	90	20	T0507
SIM0022-D5	22	5.0	90	20	T0507
SIM0022-D6	22	6.0	90	20	T0507
SIM0022-D7	22	7.0	90	20	T0507
SIM0025-D4	25	4.0	90	23	T0507
SIM0025-D5	25	5.0	90	23	T0507
SIM0025-D6	25	6.0	90	23	T0507
SIM0025-D7	25	7.0	90	23	T0507
SIM1000-D4	25.4	4.0	90	23.4	T0507
SIM1000-D5	25.4	5.0	90	23.4	T0507
SIM1000-D6	25.4	6.0	90	23.4	T0507
SIM1000-D7	25.4	7.0	90	23.4	T0507

# STAR机床微型变径套刀杆

STAR Tiny Tools Toolholders for machines

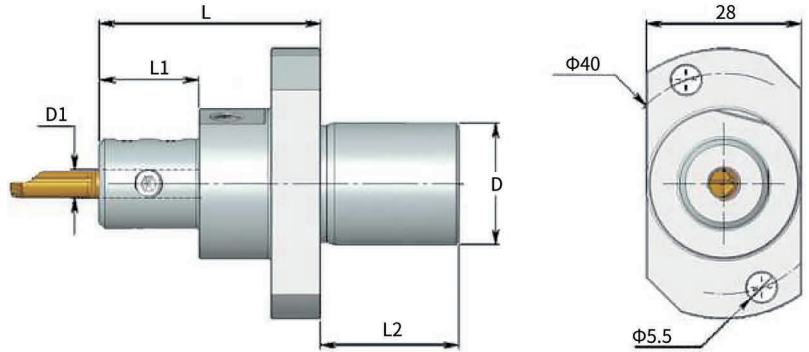

产品型号	D	D1	L	L1	L2	dp 水管孔	夹紧螺钉
SIM22S-D4	22	4.0	52	30	25	6.0	T0507
SIM22S-D5	22	5.0	52	30	25	6.0	T0507
SIM22S-D6	22	6.0	52	30	25	6.0	T0507
SIM22S-D7	22	7.0	52	30	25	6.0	T0507